

ITEM OPPORTUNITY SYNOPSIS:

Item to be Scouted

Supplier Scouting Number

NAICS Code, if known

TECHNICAL INFORMATION:	1. Describe the Item:	Please describe the item application/ the end use of item.
	Provide the item number <u>if applicable</u> : (N95 Mask vs Protective Mask).	
	2. Summary of Technical Specifications and Performance Requirements:	a. Provide dimensions / size / tolerances / performance specifications for the item.
		b. List required materials needed to make the product, Including materials of product components, if applicable.
		c. Are there applicable certification requirements to supply this item? (i.e. ISO certification) Are there any applicable regulations that apply to the production of this item? (i.e. FDA regulations or EPA regulations) Are there any other standard requirements? (i.e. ASME Standard, IEEE Standard) Please specify.
d. Describe the manufacturing processes (elaborate to provide as much detail as possible).		
f. Additional Comments:		
Is there other information that would impact the item's performance or usefulness? Please explain.		

BUSINESS INFORMATION:	Potential Business Volume Estimate (i.e., # Units Per Day, Month, Year):		
	Target Price / Unit Cost Information:		
Delivery Requirements:	When is it needed by? (Immediate, 30 Days, 6 months, etc.)		
	Describe packaging requirements (i.e., individually/ group packaging).		
	Where is this opportunity located? Is there a preferred shipping proximity - if applicable?		
Additional Comments:	How long would you like to leave this opportunity open to the National Network?		
	<input type="checkbox"/> 10 days	<input type="checkbox"/> 15 days	<input type="checkbox"/> 20 days _____ Other
	Is there other information you would like to include?		

Photos or diagrams of the item (helpful but not required).

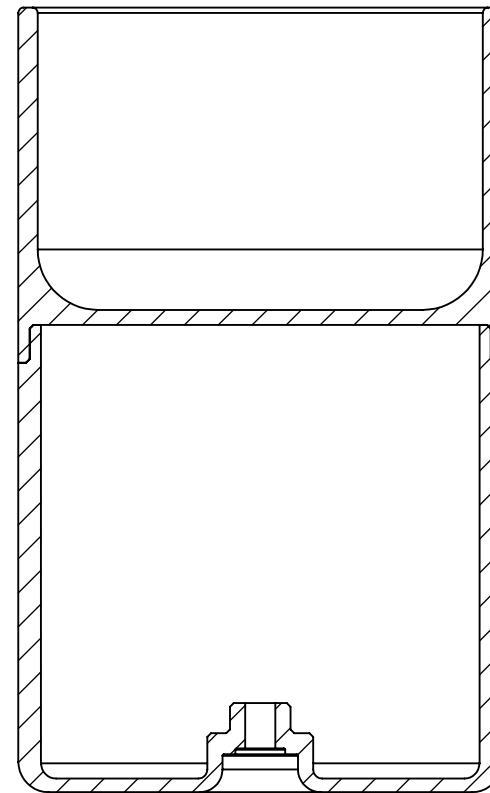
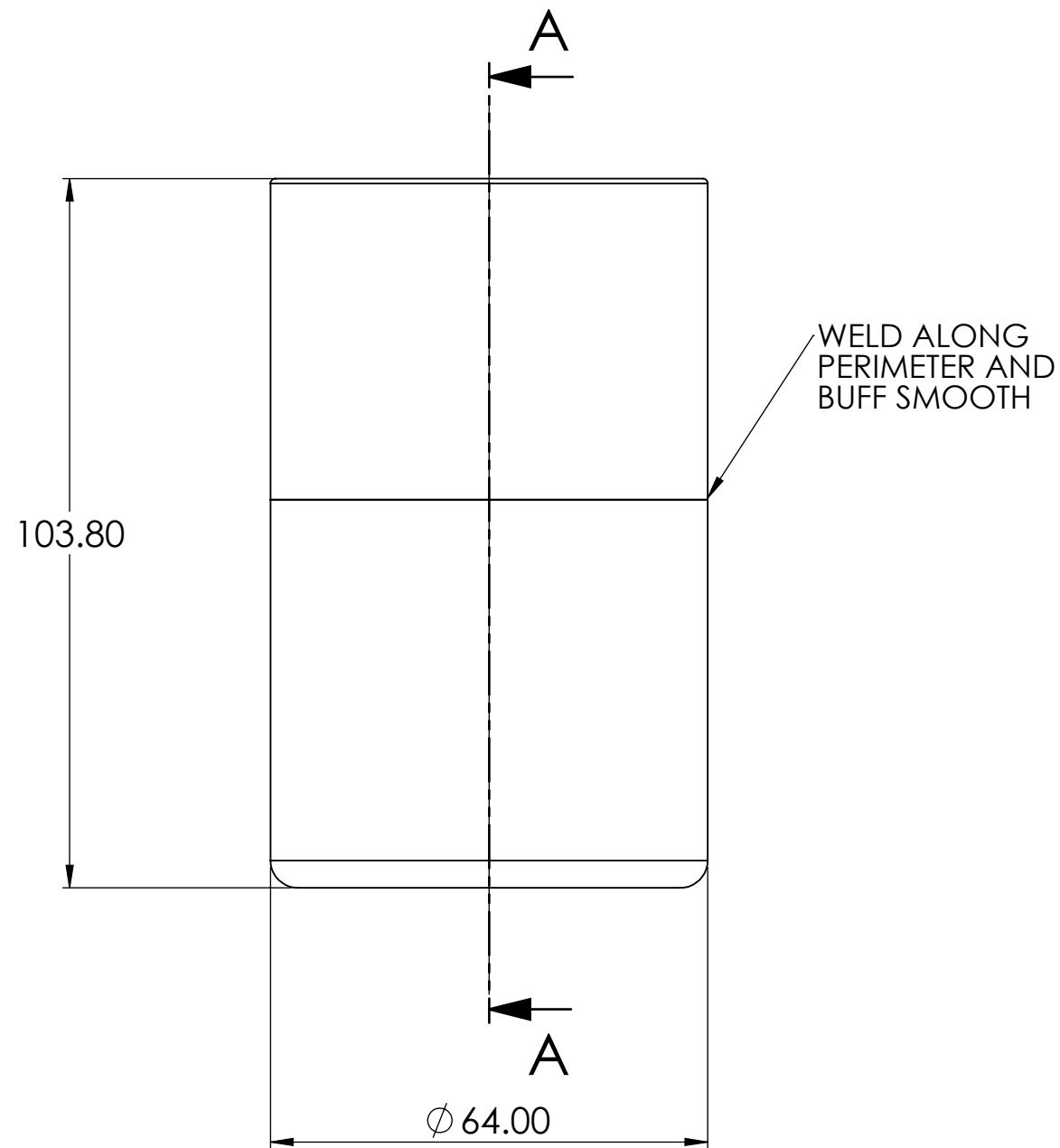

SECTION A-A
SCALE 1 : 1

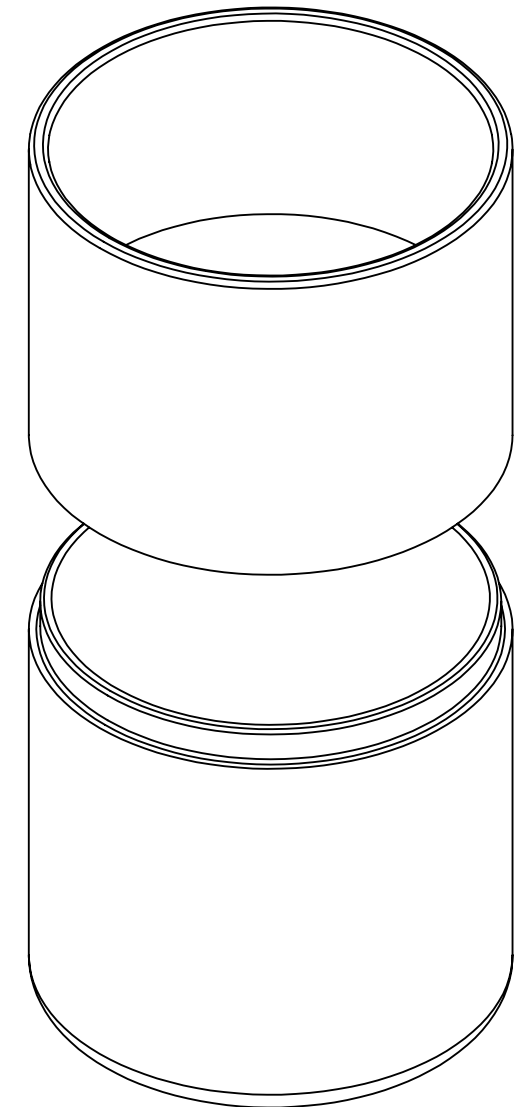

NOTICE ON REPRODUCTIONS
THE INFORMATION CONTAINED IN THIS DRAWING IS
THE SOLE PROPERTY OF PIPPY SIPS. ANY
REPRODUCTION IN PART OR AS A WHOLE WITHOUT
THE WRITTEN PERMISSION OF PIPPY SIPS IS
PROHIBITED.

REV	DESCRIPTION	DATE	PROJECT
00	INITIAL RELEASE	2/12/2021	
			MATERIAL SUS304
			FINISH Sandblasted
			THICKNESS
LAST SAVED BY: WORKACHU		2/12/2021	

UNLESS OTHERWISE SPECIFIED ALL
DIMENSIONS ARE IN mm

ONE PLACE DECIMAL: +/- 0.5mm
TWO PLACE DECIMAL: +/- 0.15mm

TITLE: PIP-proto2-puck-asy-01		
PART NO.		
REV	00	
SCALE: 1:5	SIZE B	SHEET 1 OF 1

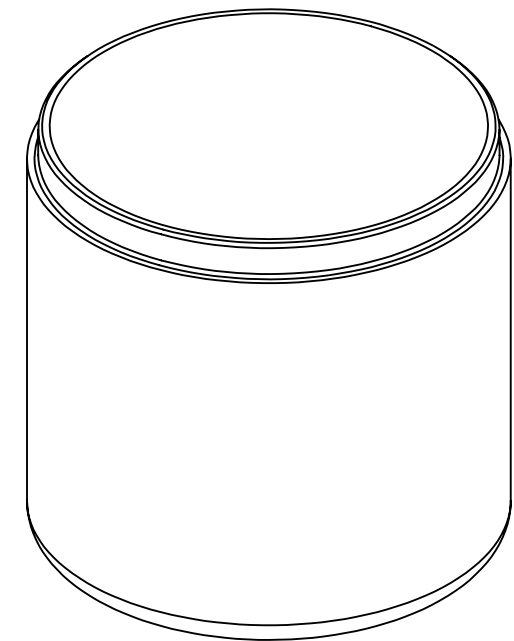
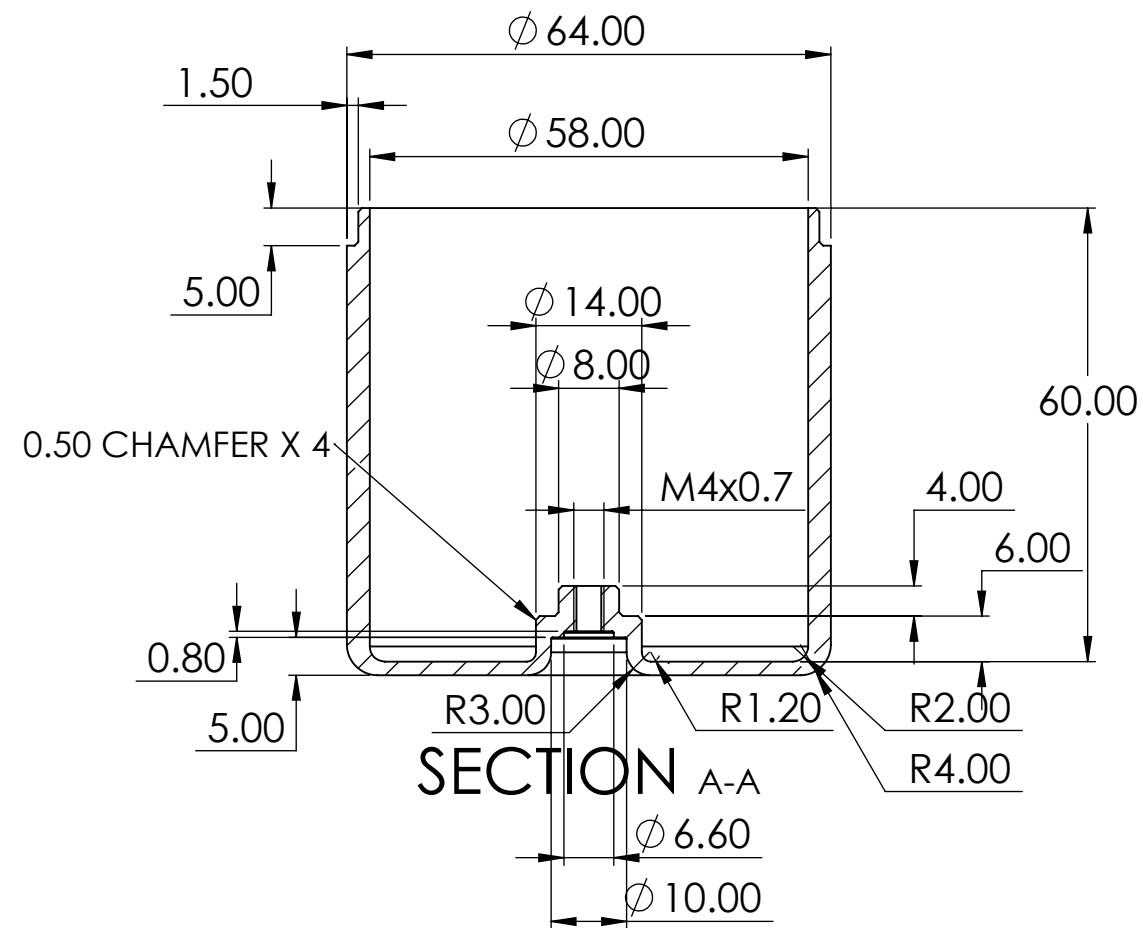
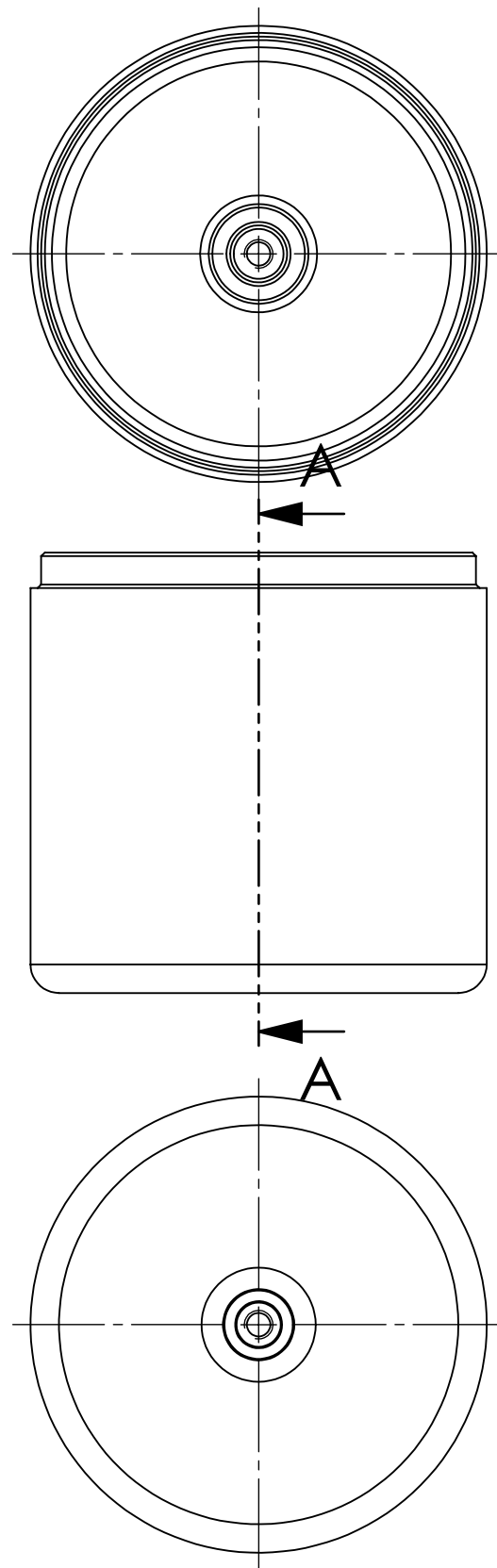

NOTICE ON REPRODUCTIONS
 THE INFORMATION CONTAINED IN THIS DRAWING IS
 THE SOLE PROPERTY OF PIPPY SIPS. ANY
 REPRODUCTION IN PART OR AS A WHOLE WITHOUT
 THE WRITTEN PERMISSION OF PIPPY SIPS IS
 PROHIBITED.

REV	DESCRIPTION	DATE	PROJECT
00	INITIAL RELEASE	2/12/2021	
			MATERIAL SUS304
			FINISH Sandblasted
			THICKNESS
LAST SAVED BY: WORKACHU		2/12/2021	

UNLESS OTHERWISE SPECIFIED ALL
 DIMENSIONS ARE IN mm

ONE PLACE DECIMAL: +/- 0.5mm
 TWO PLACE DECIMAL: +/- 0.15mm

TITLE: PIP- <u>proto2-puck-asy-</u> <u>puckbottom-01</u>		
PART NO.		
REV	00	
SCALE: 1:1	SIZE B	SHEET 1 OF 1

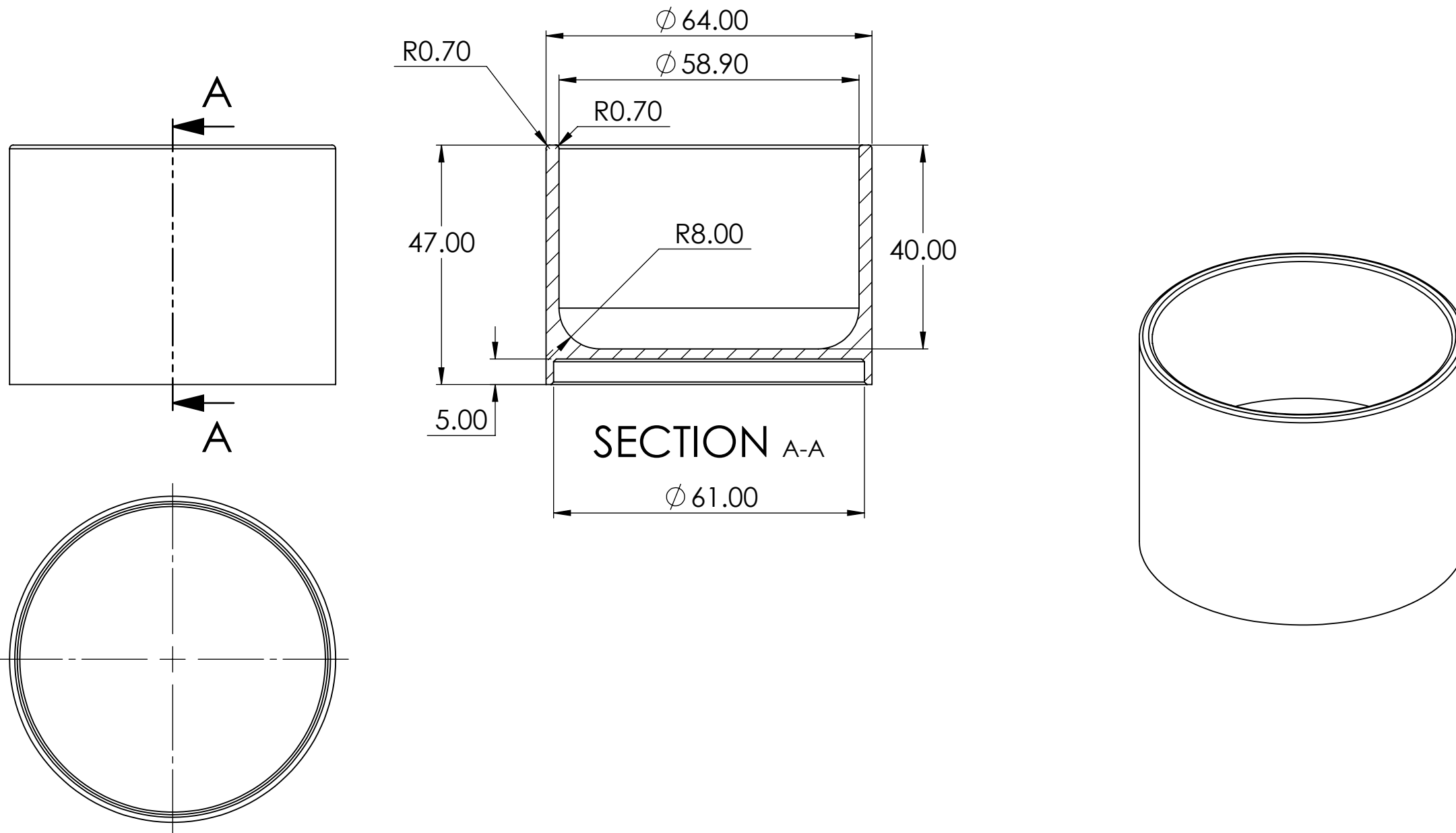

NOTICE ON REPRODUCTIONS
 THE INFORMATION CONTAINED IN THIS DRAWING IS
 THE SOLE PROPERTY OF PIPPI SIPS. ANY
 REPRODUCTION IN PART OR AS A WHOLE WITHOUT
 THE WRITTEN PERMISSION OF PIPPI SIPS IS
 PROHIBITED.

REV	DESCRIPTION	DATE	PROJECT
00	INITIAL RELEASE	2/12/2021	
			MATERIAL SUS304
			FINISH Sandblasted
	LAST SAVED BY: WORKACHU	2/12/2021	THICKNESS

UNLESS OTHERWISE SPECIFIED ALL
 DIMENSIONS ARE IN mm

ONE PLACE DECIMAL: +/- 0.5mm
 TWO PLACE DECIMAL: +/- 0.15mm

TITLE: PIP- proto2-puck-asy-		
PART NO. pucktop-01		
REV	00	
SCALE: 1:1	SIZE B	SHEET 1 OF 1